



HEB PUMP

Applications:

- Cutting, turning, milling, boring, grinding and similar applications of the machine tools,
- Especially used for deep hole boring operations due to supply 23,5 bar pressure,
- Circulation systems. HEB Pumps are used for pumping of cutting / cooling fluids.

Fluid Specifications:

- Coolants,
- Cutting oils,
- Grinding oils,
- Water,
- Fluid temperature 0...80 °C
- Kinematic viscosity 1...30 mm²/s

Materials:

Pump body	: Cast iron - DIN GG 25
Bottom plate	: Cast iron - DIN GG 25
Diffuser	: Stainless steel - DIN 4301 (AISI 304)
Impeller	: Stainless steel - DIN 4301 (AISI 304)
Strainer	: Stainless steel - DIN 4301 (AISI 304)
Pump shaft	: Stainless steel - DIN 4401 (AISI 316)
O-ring	: Viton
Mechanical seal	: C - SiC - Viton
Electric motor	: 3 phase induction motor, IE2 2 pole, 3000 rpm Protection degree IP 55

* M16x1,5 cable gland is used on HEB 02 and HEB 03 pumps.

** M25x1,5 cable gland is used on HEB 10 to HEB 20 pumps.

*** The performance curves are based on 1 mm²/s (cSt) kinematic viscosity values and 1000 kg/m³ density

**** Curve tolerance according to EN ISO 9906.

DIMENSIONS & NOMINAL VALUES

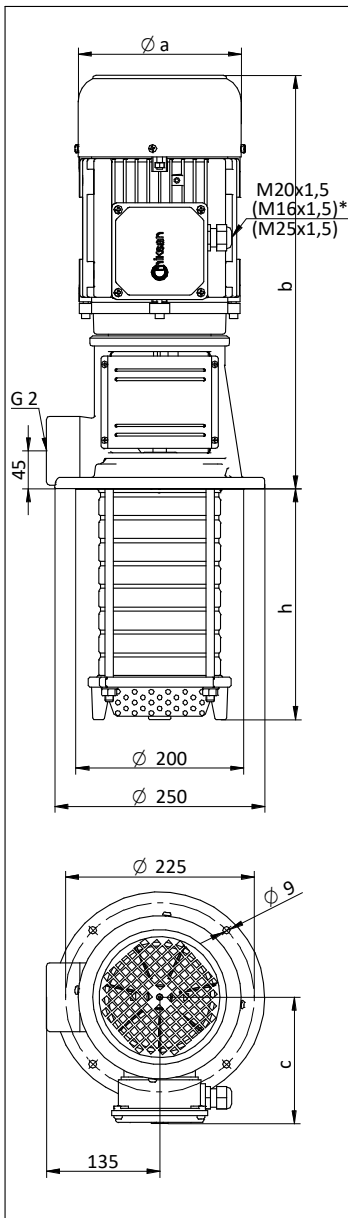

TYPE	Depth of immersion h (mm)	Dimensions (mm)			Weight (kg)	Power (kW)	Voltage V(Δ/Y)	Frequency (Hz)	Rated current (A)	Speed (rpm)
		a	b	c						
HEB 02	167	157	415	118	24.5	1.1	230/400	50	4.16/2.4	2890
HEB 03	167	176	437	139	28.5	1.5	230/400		5.72/3.3	2910
HEB 04	194	176	462	139	32.0	2.2	230/400		7.79/4.5	2905
HEB 05	221	194	489	150	38.5	3.0	230/400		10.39/6.0	2905
HEB 06	248	194	489	150	39.0	3.0	230/400		10.39/6.0	2905
HEB 07	275	194	489	150	39.5	3.0	230/400		10.39/6.0	2905
HEB 08	302	194	489	150	43.0	4.0	230/400		13.68/7.9	2900
HEB 10	356	218	502	163	49.5	5.5	230/400		17.15/9.9	2900
HEB 12	410	218	502	163	50.5	5.5	230/400		17.15/9.9	2900
HEB 14	464	258	618	177	79.0	7.5	400 Δ		14.0	2930
HEB 16	518	258	618	177	80.0	7.5	400 Δ		14.0	2930
HEB 18	572	258	618	177	81.0	7.5	400 Δ		14.0	2930
HEB 20	626	258	618	177	92.0	11.0	400 Δ		19.7	2930

Performance Curve

